

JMK PCBs PRESENTS...

PANNER

PCB AND SCHEMATIC ARTWORK (C) 2013 JMK PEDALS
VERSION 1.1: 04/30/2013

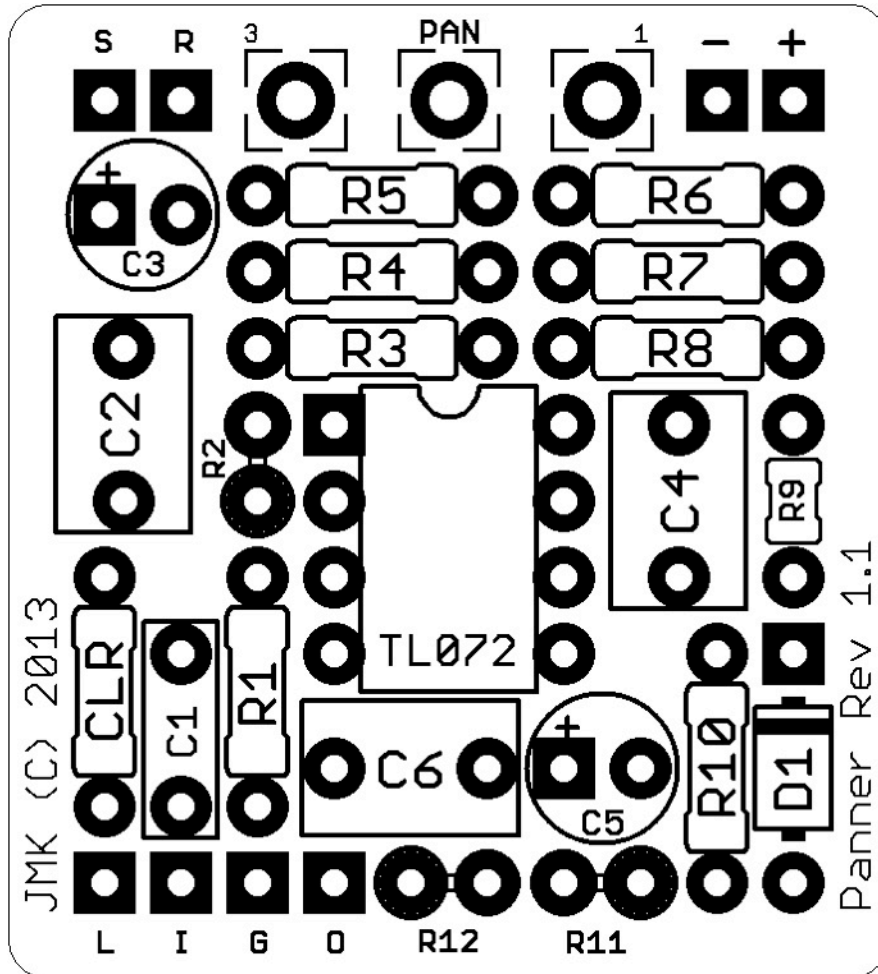

| Resistors | | | | Capacitors | | IC | |
|-----------|------|-----|------|------------|---------------------|-----------------------|--------|
| R1 | 100K | R7 | 15K | C1 | 47nF (film) | IC1 | TL072 |
| R2 | 100K | R8 | 15K | C2 | 1uF (film) | Potentiometers | |
| R3 | 15K | R9 | 100K | C3 | 47uF (electrolytic) | PAN | B10K |
| R4 | 1M | R10 | 47K | C4 | 1uF (film) | Other | |
| R5 | 1M | R11 | 47K | C5 | 47uF (electrolytic) | D1 | 1N4001 |
| R6 | 15K | R12 | 1M | C6 | 1uF (film) | CLR | 1K-10K |

This Document is designed for personal use only! Do not use this to create a product for sale without permission of it's owner: jacobkokura@gmail.com

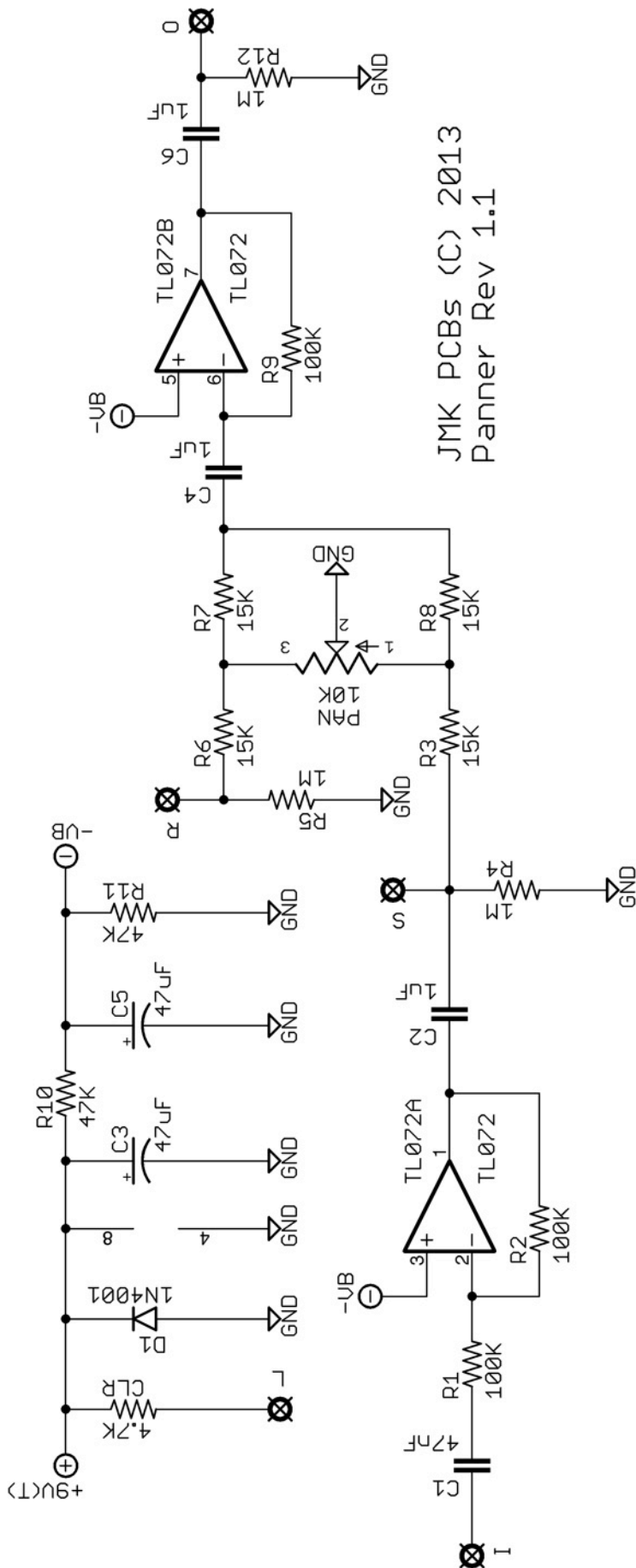

JMK PCBs (C) 2013
Panner Rev 1.1

BUILD NOTES

- The Panner is a project that has come about out of a distinct frustration with earlier and slightly less component heavy 'blend' designs, namely the blender. With the blender, which isn't our design at all but rather our attempt at it, always had an issue - you'd never be able to get pure clean signal or pure wet signal - something of either one always was left in your sound. The panner is an elegant solution, as it actually grounds the unwanted signal instead of simply introducing resistance between the signal and the output. All credit for this circuit should go to R.G. Keen, and more info on this project can be found at his website GEOfex.com
- The Panner is useful in at least two ways (please note, not all are verified):
 - It can be used as a stand alone effect in it's own enclosure, with an input and output jack, as well as a send and return jack. You can then place any effect you desire in the send and return loop, and then 'blend' them in with your signal.
 - It can be incorporated into an enclosure with one or more effect pcbs. The additional pcbs are incorporated into the loop by using the 'send' pad to connect to the input of your effect PCB, and the 'return' pad which connects to the output of the PCB. Connect the ground and +9V pads of each circuit in parallel.
- The end result should be that you have clean signal at one end of the pot's travel, and only your clean signal. At the other end of the pots travel, you should have effected signal, and only effected signal. At the centre of the pots travel, you should have equal amounts of both clean and effected signal. If you have set the level of the effect at the same volume as your clean signal, you should have no boost or difference in levels anywhere between either end of the pot's travel.
- Depending on the orientation of you potentiometer, you can hook it up as marked (lug 1 to the right pad and lug 3 to the left pad) OR you can hook it up backwards and have the blend work opposite directions:
 - With Lug 1 of your pot in pad 1 of your PCB, clean signal only will be at the CW end of the pot's travel.
 - With Lug 3 of your pot in pad 1 of your PCB, clean signal only will be at the CCW end of the pot's travel.
- Hooking up the PCB is pretty simple, but to clarify: L = the connection for the + end of an LED (CLR is marked); I = PCB Input; G = Ground for the Switch; O = PCB Output; + = 9V input; - = Ground for DC Jack; S = Send for the loop of the panner; R = Return for the loop of the panner

TRUE BYPASS WIRING DIAGRAM

